

## ECU Technical Data Low Lift Pallet Truck

---

[ECU 14](#)

[ECU 14 Full Lead](#)

[ECU 16](#)

[ECU 18](#)

[ECU 20](#)

[ECU 25](#)

[ECU 30](#)





Distinguishing marks	1.1 Manufacturer		STILL	STILL	STILL	STILL	STILL	STILL	STILL	STILL	STILL	STILL	
	1.2 Manufacturer's type designation		ECU 14	ECU 14 Full Lead*	ECU 16	ECU 18	ECU 20	ECU 25	ECU 30				
1.3 Drive			Electric	Electric	Electric	Electric	Electric	Electric	Electric				
1.4 Operator type			Pedestrian	Pedestrian	Pedestrian	Pedestrian	Pedestrian	Pedestrian	Pedestrian				
1.5 Rated capacity/rated load			kg 1400	1400	1600	1600	1800	1800	2000	2500	2500	3000 <sup>1</sup>	3000 <sup>1</sup>
1.6 Load centre distance			mm 600	600	600	600	600	600	600	600	600	600	600
1.8 Load distance, centre of drive axle to fork			mm 914	914	914	914	914	914	914	914	914	914	914
1.9 Wheel base			mm 1275	1210	1275	1342	1275	1342	1342	1342	1414	1342	1414
2.1 Service weight incl. battery			kg 325	327	432	512	432	512	512	545	643	545	643
2.2 Axle loading laden	drive end/load end		kg 591/1134	593/1134	723/1309 <sup>2</sup>	762/1350 <sup>3</sup>	772/1460 <sup>2</sup>	808/1503 <sup>3</sup>	855/1657 <sup>3</sup>	992/2053	1031/2112	1109/2436	1142/2501
2.3 Axle loading unladen	drive end/load end		kg 251/74	253/74	336/96 <sup>2</sup>	395/117 <sup>3</sup>	336/96 <sup>2</sup>	395/117 <sup>3</sup>	395/117 <sup>3</sup>	414/131	484/159	414/131	484/159
3.1 Tyres			Polyurethane		Polyurethane	Polyurethane	Polyurethane	Polyurethane	Polyurethane	Polyurethane	Polyurethane	Polyurethane	Polyurethane
3.2 Tyre size	drive end		mm $\phi$ 230 x 75	$\phi$ 230 x 75	$\phi$ 230 x 75	$\phi$ 230 x 75	$\phi$ 230 x 75	$\phi$ 230 x 75	$\phi$ 230 x 75	$\phi$ 230 x 75	$\phi$ 230 x 75	$\phi$ 230 x 75	$\phi$ 230 x 75
3.3 Tyre size	load end		mm $\phi$ 85 x 100	$\phi$ 85 x 100	$\phi$ 85 x 100	$\phi$ 85 x 100	$\phi$ 85 x 100	$\phi$ 85 x 100	$\phi$ 85 x 100	$\phi$ 85 x 80	$\phi$ 85 x 80	$\phi$ 85 x 80	$\phi$ 85 x 80
3.4 Support castor size			mm $\phi$ 100 x 40	$\phi$ 100 x 40	$\phi$ 100 x 40	$\phi$ 100 x 40	$\phi$ 100 x 40	$\phi$ 100 x 40	$\phi$ 100 x 40	$\phi$ 100 x 40	$\phi$ 100 x 40	$\phi$ 100 x 40	$\phi$ 100 x 40
3.5 Number of wheels (x = driven)	drive end/load end		1x 2/2	1x 2/2	1x 2/2	1x 2/2	1x 2/2	1x 2/2	1x 2/2	1x 2/4	1x 2/4	1x 2/4	1x 2/4
3.6 Tread	drive end		mm 458	458	458	458	458	458	458	458	458	458	458
3.7 Tread	load end		mm 350/390/510	350/390/510	350/390/510	350/390/510	350/390/510	350/390/510	350/390/510	350/390/510	350/390/510	350/390/510	350/390/510
4.4 Lift			mm 123	123	123	123	123	123	123	123	123	123	123
4.9 Height drawbar in driving position	min./max.		mm 800/1240	800/1240	800/1240	800/1240	800/1240	800/1240	800/1240	800/1256	800/1256	800/1256	800/1256
4.15 Fork height, lowered			mm 85	85	85	85	85	85	85	85	85	85	85
4.19 Overall length			mm 1660	1595	1660	1727	1660	1727	1727	1727	1799	1727	1799
4.20 Length to face of forks			mm 510	445	510	577	510	577	577	577	649	577	649
4.21 Overall width			mm 720	720	720	720	720	720	720	720	720	720	720
4.22 Fork dimensions	DIN ISO 2331		mm 52/170/1150	52/170/1150	52/170/1150	52/170/1150	52/170/1150	52/170/1150	52/170/1150	52 (57 <sup>3</sup> )/170/1150	52 (57 <sup>3</sup> )/170/1150	52 (57 <sup>3</sup> )/170/1150	52 (57 <sup>3</sup> )/170/1150
4.25 Overall fork width			mm 520/560/680	520/560/680	520/560/680	520/560/680	520/560/680	520/560/680	520/560/680	520/560/680	520/560/680	520/560/680	520/560/680
4.32 Ground clearance, centre of wheel base			mm 36	36	36	36	36	36	36	36 (30 <sup>3</sup> )	36 (30 <sup>3</sup> )	36 (30 <sup>3</sup> )	36 (30 <sup>3</sup> )
4.34.1 Aisle width for pallets 1000 x 1200 crossways			mm 1771 <sup>4</sup>	1706	1771 <sup>4</sup>	1838 <sup>4</sup>	1771 <sup>4</sup>	1838 <sup>4</sup>	1838 <sup>4</sup>	1838 <sup>3</sup>	1909 <sup>3</sup>	1838 <sup>3</sup>	1909 <sup>3</sup>
4.34.2 Aisle width for pallets 800 x 1200 lengthways			mm 1971 <sup>4</sup>	1906	1971 <sup>4</sup>	2038 <sup>4</sup>	1971 <sup>4</sup>	2038 <sup>4</sup>	2038 <sup>4</sup>	2038 <sup>3</sup>	2109 <sup>3</sup>	2038 <sup>3</sup>	2109 <sup>3</sup>
4.35 Turning radius			mm 1485 <sup>4</sup>	1420	1485 <sup>4</sup>	1552 <sup>4</sup>	1485 <sup>4</sup>	1552 <sup>4</sup>	1552 <sup>4</sup>	1552 <sup>3</sup>	1623 <sup>3</sup>	1552 <sup>3</sup>	1623 <sup>3</sup>
5.1 Travel speed	laden/unladen		km/h 5/5	5/5	6/6	6/6	6/6	6/6	6/6	6/6	6/6	6/6	6/6
5.2 Lift speed	laden/unladen		km/h 0.039/0.047	0.039/0.047	0.039/0.047	0.039/0.047	0.039/0.047	0.039/0.047	0.039/0.047	0.046/0.060	0.046/0.060	0.044/0.060	0.044/0.060
5.3 Lowering speed	laden/unladen		m/s 0.072/0.028	0.072/0.028	0.087/0.037	0.087/0.037	0.044/0.044	0.044/0.044	0.044/0.044	0.045/0.046	0.045/0.046	0.045/0.046	0.045/0.046
5.8 Max. gradeability kB 5	laden/unladen		% 10.00/25.00	10.00/25.00	8.00/25.00	8.00/25.00	7.30/25.00	7.30/25.00	6.60/25.00	8.00/24.04	8.00/24.04	6.70/24.04	6.70/24.04
5.10 Service brake			Electric	Electric	Electric	Electric	Electric	Electric	Electric	Electromagnetic	Electromagnetic	Electromagnetic	Electromagnetic
6.1 Drive motor rating S2 60 min			kW 1.0	1.0	1.0	1.0	1.0	1.0	1.0	1.5	1.5	1.5	1.5
6.2 Lift motor rating at S3 15 %			kW 1.0	1.0	1.0	1.0	1.0	1.0	1.0	2.2	2.2	2.2	2.2
6.3 Battery according to DIN 43531/35/36 A, B, C, no			-	-	British Standard	DIN 43535 B	British Standard	DIN 43535 B	DIN 43535 B	DIN 43535 B	DIN 43535 B	DIN 43535 B	DIN 43535 B
6.4 Battery voltage/nominal capacity K <sub>s</sub>			V/Ah 2x 12/44	2x 12/58	24/110 (150)	24/200 (250)	24/110 (150)	24/200 (250)	24/200 (250)	24/200 (250)	24/375	24/200 (250)	24/375
6.5 Battery weight $\pm$ 5 % (depends on make)			kg 36.4	38.2	123 (152)	150 (220)	123 (152)	150 (220)	150 (220)	150 (220)	305	150 (220)	305
6.6 Energy consumption according to VDI cycle			kWh/h 0.30	0.30	0.36	0.36	0.37	0.37	0.40	0.54	0.61	0.61	0.64
8.1 Drive control			Electronic	Electronic	Electronic	Electronic	Electronic	Electronic	Electronic	Electronic	Electronic	Electronic	Electronic
8.4 Sound pressure level at driver's seat			dB (A) <70	<70	<70	<70	<70	<70	<70	<70	<70	<70	<70

\* Available from 01/10/2014

<sup>1</sup> For fork length > 1600 mm only with short wheel base

<sup>2</sup> For fork length > 1600 mm

<sup>3</sup> Values for tiller in working position for narrow areas and 90°-steering angle

<sup>4</sup> Geometrical limit for versions with a fork length of 2400 mm and a standard wheel base

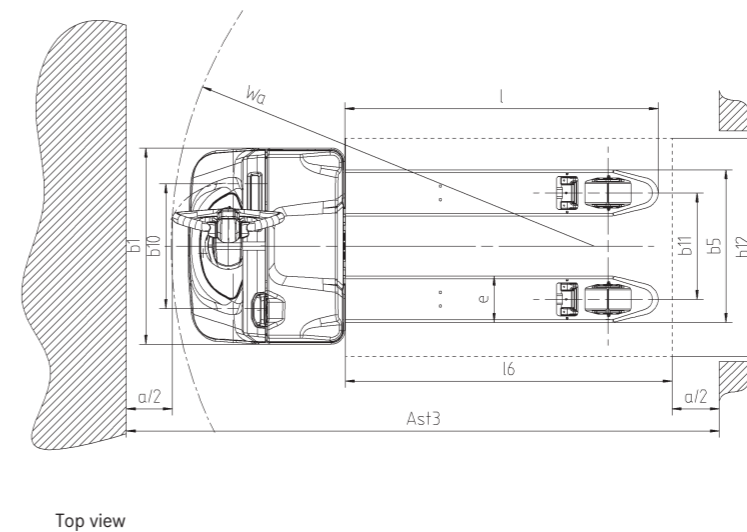
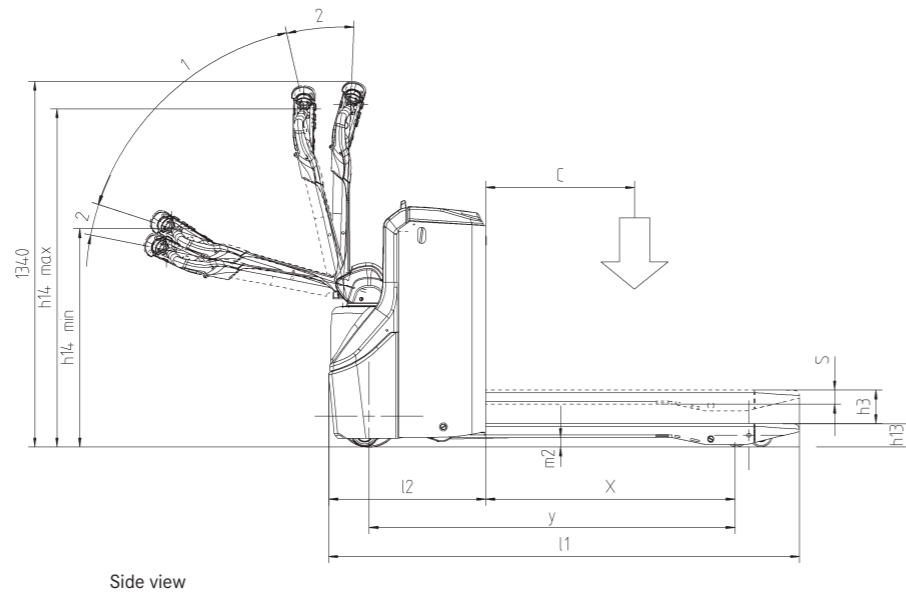

## ECU Low Lift Pallet Truck Battery Tables

Version with pressure rod

Fork length $\ell$ (mm)	Load distance x (mm)	Turning radius $W_a$ (mm)				
		ECU 14/16/18/20		ECU 25		ECU 30
		150 Ah	250 Ah	250 Ah	375 Ah	375 Ah
980	744	1315	1382	1382	1454	1454
1150	914	1485	1552	1552	1623	1623
1200	964	-	-	1602	1673	1673
1450	1214	1784	1851	1851	1923	1923
1600	1364	1934	2001	2001	2073	2073

Version with drawbar

Fork length $\ell$ (mm)	Load distance x (mm)	Turning radius $W_a$ (mm)				
		ECU 14/16/18/20		ECU 25		ECU 30
		150 Ah	250 Ah	250 Ah	375 Ah	375 Ah
1980	1694	-	-	2331	2402	-
1980	1491	-	-	2128	2200	2200
2160	1874	-	-	2510	2582	-
2160	1618	-	-	2254	2326	2326
2400	2114	-	-	2750	2822	-
2400	1744	-	-	2380	2452	2452

## Detailed Photos



Battery cable



Tiller

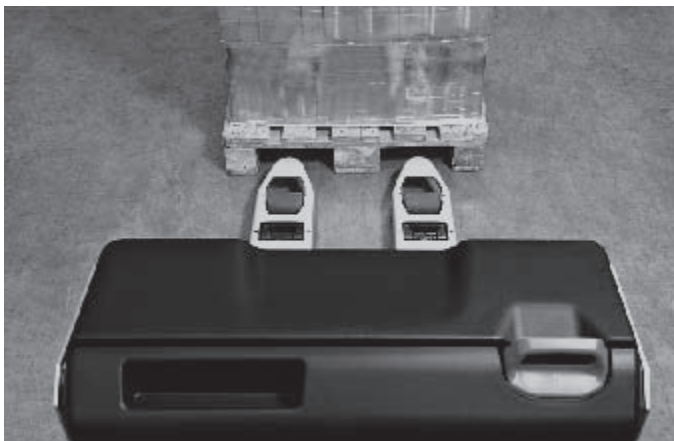

Free view on forks



## ECU Low Lift Pallet Truck

---

Can be manoeuvred in confined spaces: creep speed switch on tiller head

Impressive goods handling: lifting capacity of up to three tonnes

Safe and efficient due to optimum view on tip of the forks



---

### ECU

The ECU low lift pallet truck is perfectly suited to the horizontal transport of up to 3,000 kg over short distances. Its compact size and exceptional manoeuvrability make it the ideal warehouse assistant even in confined spaces, for example for the preparation of goods. The cleverly positioned creep speed switch is an optional extra that is also of great advantage. It is located on the tiller head, meaning smooth and precise manoeuvring is possible even when the tiller is vertical. As a result of the well thought-out tiller design and the intelligent arrangement of the control elements, the ECU can be fully operated with one hand, whether the operator is left- or right-handed. Boasting a chassis made of robust materials, which can withstand even severe impacts without being deformed, and an extremely low-wear drive wheel, the ECU impresses with low operating costs even when in continuous use.

---

### ECU Full Lead

The ECU Full Lead is a real bundle of energy. Thanks to its full lead battery, the manoeuvrable pallet truck can be charged up very quickly, and its modern energy source also allows for interim charging. The small size of its battery also means that the ECU Full Lead is particularly compact. Consequently, safe and precise operation is guaranteed even in confined spaces – whether loading and unloading lorries via a ramp or working in narrow warehouse gangways or supermarket aisles. Of course, the ECU Full Lead also comes with all of the usual advantages of the reliable ECU product line, such as the integrated charger, which saves the space and money which would be needed for an external charging station, and the energy recovery when braking.

---

## Extensive Equipment

---

### Power

- High handling performance thanks to lifting capacity of up to three tonnes
- Full power: low-maintenance and enclosed rotary current drive

---

### Precision

- Can be manoeuvred even in confined spaces thanks to optional creep speed switch on tiller head
- Optimum view on tip of the forks
- Fast and precise: rounded forks are easier to thread into the pallets

---

### Ergonomics

- Control elements that are well suited to left and right-handed operators
- Fast operation, without needing to look at the buttons: buttons can be clearly differentiated by their tactile characteristics

---

### Compactness

- Impressive reloading of pallets: compact size allows for quick and safe operation
- Perfect in confined spaces: extremely mobile thanks to short and narrow design

---

### Safety

- The reliable impact switch protects the health of the operator
- Unauthorised access not possible: series access authorisation via PIN code

---

### Environmental Responsibility

- Very few noise emissions
- Energy recovery when braking
- Over 95 percent of all materials used are recyclable

# ECU Low Lift Pallet Truck Equipment Variants



	ECU 14	ECU 14 Full Lead*	ECU 16	ECU 18	ECU 20	ECU 25	ECU 30
General	Easy-grip tiller for left and right-handed operators	●	●	●	●	●	●
	Various fork lengths	○	○	○	○	○	○
	DIN A4 writing pad with accessories bracket	○	○	○	○	○	○
	Reduced speed with vertical tiller	○	○	○	○	○	○
	Cold storage version	○	○	○	○	○	○
Drive	Drive wheel tyres, polyurethane, 230 x 75 mm	●	●	●	●	●	●
	Drive wheel tyres, polyurethane, profiled, 230 x 75 mm	○	○	○	○	○	○
	Drive wheel tyres, polyurethane, anti-static, 230 x 75 mm	○	○	○	○	○	○
	Drive wheel tyres, solid rubber	○	○	○	○	○	—
	Load roller tyres, polyurethane, single, 85 x 100 mm	●	●	●	●	●	—
	Load roller tyres, polyurethane, tandem, 85 x 80 mm	○	○	○	○	○	●
Safety	PIN code access	○	○	○	○	○	○
Battery system	Lateral battery changing with roller track	—	—	—	—	○	○
	Battery changing using crane	—	—	●	●	●	●
	2 maintenance-free 12 V/44 Ah block batteries	●	—	—	—	—	—
	2 maintenance-free and quickly loadable full lead block batteries 12 V / 58 Ah	—	●	—	—	—	—
	Battery compartment for 110 Ah to 150 Ah batteries	—	—	●	●	—	—
	Battery compartment for 200 Ah to 250 Ah batteries	—	—	○	○	●	●
	Battery compartment for 300 Ah to 375 Ah batteries	—	—	—	—	—	○
	Battery compartment for 300 Ah to 375 Ah batteries, for lateral battery changing	—	—	—	—	—	○
	Built-in charger for full lead batteries	—	●	—	—	—	—
	Built-in charger for gel batteries	●	—	○	○	○	○
	Built-in charger for wet-cell batteries	—	—	○	○	○	○

\* Available from 01/10/2014

● Standard ○ Option — Not available



STILL Materials Handling Ltd

Aston Way

Leyland Preston

PR26 7UX

Tel.: +44 (0)845 603 6827

Fax: +44 (0)1772 454668

info@still.co.uk

**For further information please visit:**

**[www.still.co.uk](http://www.still.co.uk)**

STILL Materials Handling Ltd

19 Hennock Road

Marsh Barton Trading Estate

Exeter

EX2 8RU

Tel.: +44 (0)1392 435151

Fax: +44 (0)1392 824328

STILL Materials Handling Ltd

George Henry Road

Graet Bridge

West Midlands

DY4 7BZ

Tel.: +44 (0)845 603 6827

Fax: +44 (0)121 520 9945

STILL is certified in the following areas: Quality management, occupational safety, environmental protection and energy management.



first in intralogistics